

SMD POWER INDUCTOR

【SDRH8D28-SERIES】

DIMENSIONS & RECOMMENDED PATTERN

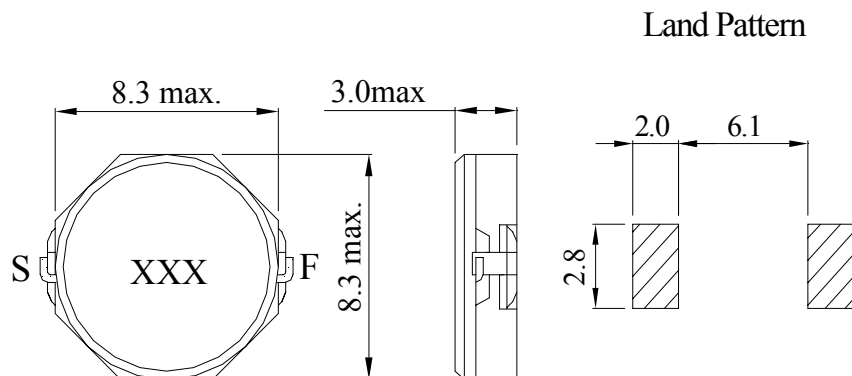

Unit: mm

※ FEATURES

- Applications : DC to DC converter of portable equipment, camcorder, LCD television set, digital camera, P.D.A., notebook

SELECTION GUIDE FOR STANDARD COILS

SDE Part Number	Inductance (μ H)	Tolerance (%)	DC Resistance (Ω) Max	Inductance Decrease Current (A) Max	Temperature Rise Current (A) Max
SDRH8D28 - 1R0N	1.0	$\pm 30\%$	0.0110	6.50	7.00
SDRH8D28 - 2R5N	2.5	$\pm 30\%$	0.0156	4.50	6.40
SDRH8D28 - 3R3N	3.3	$\pm 30\%$	0.0182	4.00	6.00
SDRH8D28 - 4R7N	4.7	$\pm 30\%$	0.0247	3.40	4.50
SDRH8D28 - 6R8N	6.8	$\pm 30\%$	0.0390	2.80	3.40
SDRH8D28 - 100N	10.0	$\pm 30\%$	0.0470	2.50	3.20
SDRH8D28 - 150N	15.0	$\pm 30\%$	0.0690	1.90	2.35
SDRH8D28 - 220N	22.0	$\pm 30\%$	0.0990	1.60	1.85
SDRH8D28 - 330N	33.0	$\pm 30\%$	0.1560	1.30	1.45
SDRH8D28 - 470N	47.0	$\pm 30\%$	0.1950	1.15	1.30
SDRH8D28 - 680N	68.0	$\pm 30\%$	0.2860	0.92	0.98
SDRH8D28 - 101N	100.0	$\pm 30\%$	0.4300	0.75	0.80

※ GENERAL SPECIFICATION:

- Inductance drop =35% typ. at IDC.
- $\Delta T=40^{\circ}\text{C}$ rise at IDC.
- Operating Temperature : $-40^{\circ}\text{C} \sim +85^{\circ}\text{C}$
- Test Freq. : 100KHz / 1V.