

【SDRH5D18-SERIES】

DIMENSIONS & RECOMMENDED PATTERN

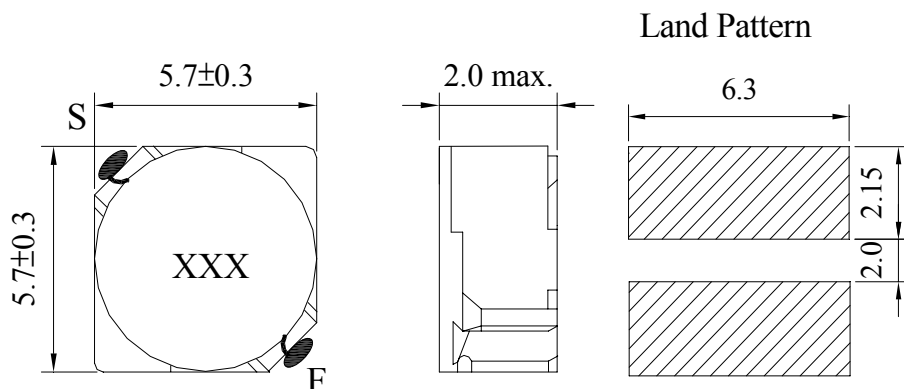

Unit: mm

※ FEATURES

- Applications : DC to DC converter of portable equipment, camcorder, LCD television set, digital camera, P.D.A., notebook

SELECTION GUIDE FOR STANDARD COILS

SDE Part Number	Inductance	Tolerance	DC Resistance	Inductance Decrease Current
	(μ H)	(%)	(Ω) Max	(A) Max
SDRH5D18 - 4R1N	4.1	$\pm 30\%$	0.057	1.95
SDRH5D18 - 5R4N	5.4	$\pm 30\%$	0.076	1.60
SDRH5D18 - 6R2N	6.2	$\pm 30\%$	0.096	1.40
SDRH5D18 - 8R9N	8.9	$\pm 30\%$	0.116	1.25
SDRH5D18 - 100N	10.0	$\pm 30\%$	0.124	1.20
SDRH5D18 - 120N	12.0	$\pm 30\%$	0.153	1.10
SDRH5D18 - 150N	15.0	$\pm 30\%$	0.196	0.97
SDRH5D18 - 180N	18.0	$\pm 30\%$	0.210	0.85
SDRH5D18 - 220N	22.0	$\pm 30\%$	0.290	0.80
SDRH5D18 - 270N	27.0	$\pm 30\%$	0.330	0.75
SDRH5D18 - 330N	33.0	$\pm 30\%$	0.386	0.65
SDRH5D18 - 390N	39.0	$\pm 30\%$	0.520	0.57
SDRH5D18 - 470N	47.0	$\pm 30\%$	0.595	0.54
SDRH5D18 - 560N	56.0	$\pm 30\%$	0.665	0.50
SDRH5D18 - 680N	68.0	$\pm 30\%$	0.840	0.43
SDRH5D18 - 820N	82.0	$\pm 30\%$	0.978	0.41
SDRH5D18 - 101N	100.0	$\pm 30\%$	1.200	0.36
SDRH5D18 - 121N	120.0	$\pm 30\%$	1.500	0.33
SDRH5D18 - 151M	150.0	$\pm 20\%$	1.710	0.31

【SDRH5D18-SERIES】

SELECTION GUIDE FOR STANDARD COILS

SDE Part Number	Inductance	Tolerance	DC Resistance	Inductance Decrease Current
	(μ H)	(%)	(Ω) Max	(A) Max
SDRH5D18 - 181M	180.0	$\pm 20\%$	2.240	0.28
SDRH5D18 - 221M	220.0	$\pm 20\%$	2.440	0.23
SDRH5D18 - 271M	270.0	$\pm 20\%$	3.380	0.21
SDRH5D18 - 331M	330.0	$\pm 20\%$	4.340	0.18

※ GENERAL SPECIFICATION:

- a. Inductance drop =35% typ. at IDC.
- b. $\Delta T=30^{\circ}\text{C}$ rise at IDC.
- c. Operating Temperature : $-40^{\circ}\text{C} \sim +85^{\circ}\text{C}$
- d. Test Freq. : 100KHz / 0.1V.