

SMD POWER INDUCTOR

【SDRH4D28】

DIMENSIONS & RECOMMENDED PATTERN

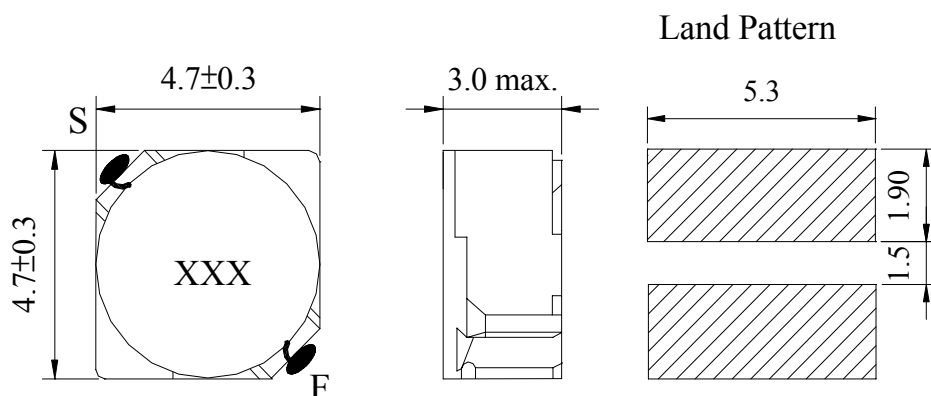

Unit: mm

※ FEATURES

- Applications : DC to DC converter of portable equipment, camcorder, LCD television set, digital camera, P.D.A., notebook

SELECTION GUIDE FOR STANDARD COILS

SDE Part Number	Inductance	Tolerance	DC Resistance	Inductance Decrease Current
	(μ H)	(%)	(Ω) Max	(A) Max
SDRH4D28 - 1R2N	1.2	$\pm 30\%$	0.0236	2.56
SDRH4D28 - 1R8N	1.8	$\pm 30\%$	0.0275	2.20
SDRH4D28 - 2R2N	2.2	$\pm 30\%$	0.0313	2.04
SDRH4D28 - 2R7N	2.7	$\pm 30\%$	0.0433	1.60
SDRH4D28 - 3R3N	3.3	$\pm 30\%$	0.0492	1.57
SDRH4D28 - 3R9N	3.9	$\pm 30\%$	0.0648	1.44
SDRH4D28 - 4R7N	4.7	$\pm 30\%$	0.0720	1.32
SDRH4D28 - 5R6N	5.6	$\pm 30\%$	0.1009	1.17
SDRH4D28 - 6R8N	6.8	$\pm 30\%$	0.1089	1.12
SDRH4D28 - 8R2N	8.2	$\pm 30\%$	0.1175	1.04
SDRH4D28 - 100M	10.0	$\pm 20\%$	0.1283	1.00
SDRH4D28 - 120M	12.0	$\pm 20\%$	0.1316	0.84
SDRH4D28 - 150M	15.0	$\pm 20\%$	0.1490	0.76
SDRH4D28 - 180M	18.0	$\pm 20\%$	0.1660	0.72
SDRH4D28 - 220M	22.0	$\pm 20\%$	0.2350	0.70
SDRH4D28 - 270M	27.0	$\pm 20\%$	0.2610	0.58
SDRH4D28 - 330M	33.0	$\pm 20\%$	0.3780	0.56
SDRH4D28 - 390M	39.0	$\pm 20\%$	0.3837	0.50
SDRH4D28 - 470M	47.0	$\pm 20\%$	0.5870	0.48

SMD POWER INDUCTOR

【SDRH4D28】

SELECTION GUIDE FOR STANDARD COILS

SDE Part Number	Inductance	Tolerance	DC Resistance	Inductance Decrease Current
	(μ H)	(%)	(Ω) Max	(A) Max
SDRH4D28 - 560M	56.0	$\pm 20\%$	0.6245	0.41
SDRH4D28 - 680M	68.0	$\pm 20\%$	0.6990	0.35
SDRH4D28 - 820M	82.0	$\pm 20\%$	0.9148	0.32
SDRH4D28 - 101M	100.0	$\pm 20\%$	1.0200	0.29
SDRH4D28 - 121M	120.0	$\pm 20\%$	1.2700	0.27
SDRH4D28 - 151M	150.0	$\pm 20\%$	1.3500	0.24
SDRH4D28 - 181M	180.0	$\pm 20\%$	1.5400	0.22
SDRH4D28 - 221M	220.0	$\pm 20\%$	1.7200	0.20
SDRH4D28 - 271M	270.0	$\pm 20\%$	1.9500	0.16
SDRH4D28 - 331M	330.0	$\pm 20\%$	2.6600	0.14
SDRH4D28 - 391M	390.0	$\pm 20\%$	2.8300	0.13

※ GENERAL SPECIFICATION:

- Inductance drop =35% typ. at IDC.
- $\Delta T=40^{\circ}\text{C}$ rise at IDC.
- Operating Temperature : $-40^{\circ}\text{C} \sim +85^{\circ}\text{C}$
- Test Freq. : 100KHz / 0.1V.